

## Leakage Sensor

# LS 50

---

Documentation LS 50

Art. No.: 641602  
Issued: 02/2022

---



**SGB GMBH**  
Hofstr. 10  
57076 Siegen  
GERMANY

Please, read the  
instructions before  
starting any work!



**Content information for documentation**

1. Technical description	7 pages
2. Drawings for technical description	6 pages
3. Appendix A	7 pages
4. Appendix TD (technical data)	1 page
5. Declaration of Conformity	1 page
6. TÜV test report	7 pages
7. Warranty	1 page



<b><u>Table of contents</u></b>	<b>Page</b>
1 Object.....	2
2 Area of application.....	2
2.1 Location for use.....	2
2.2 Liquids which can be monitored .....	2
3 Function .....	2
3.1 Functional description.....	2
3.2 Operating statuses (lamp display signals) .....	3
3.3 Button functions .....	3
4 Installation instructions .....	3
4.1 Basic instructions .....	3
4.2 Installation of the leak display device.....	4
4.3 "Save alarm" function .....	4
4.4 Installation of the electrical connection cable.....	4
4.5 Electrical connection.....	4
4.6 Installation examples.....	5
5 Commissioning.....	6
6 Operating instructions.....	6
6.1 General instructions.....	6
6.2 Maintenance/functional test.....	6
6.3 Intended use .....	7
6.4 Alarms.....	7
7 Markings.....	7
8 Index .....	7

### **Drawings:**

Block diagram of the leak display device A	SL – 852 500
Block diagram of the leak display device C	SL – 852 600
Housing views	A – 105 500-520
Installation examples	M1 – 105 500-520
	to M3 – 105 500-520

### **Appendix:**

Appendix A: sensors and their data

Appendix TD: Technical data

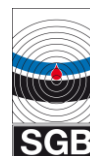

## 1. Object

Leakage sensor, comprising leak display device and sensor, for displaying liquids. The leak display device is available in different designs in conjunction with different sensors (see appendix A):

Indicating unit A: Top-hat rail installation, connection of one sensor as per appendix A possible, only optical and potential-free alarm signals.

Indicating unit C: Wall installation, connection of two sensors as per appendix A.

**CAUTION:** The device may not be adequately protected if it is not used as specified by the manufacturer.

## 2. Area of application

### 2.1. Location for use

Spaces or areas in which the appearance of liquid due to an increase in the liquid is to be signaled.

For example: Collection space, monitoring room, collection pan, inspection or access shaft, filling shaft, closed spaces with internal overpressure or negative pressure.<sup>1</sup>

### 2.2. Liquids which can be monitored

- Liquids which are a hazard to water with a flash point above 60°C (Germany: >55°C acc. to TRGS 509 and 751).
- The sensor must be resistant to the liquid being detected.
- Appendix A provides further details (data sheets for the sensors which can be used), e.g., the required physical properties of the liquid being monitored in conjunction with the sensor to be used.

## 3. Function

### 3.1. Functional description

The LS 50 leakage sensor comprises a leak display device and one or more sensors.

In normal mode the green "operation" signal lamp indicates that a sensor is connected and ready for operation.

If there is an increase in liquid (see appendix A for activation level) the sensor triggers the transmission of an alarm signal to the leak display device. At the same time the potential-free contacts change to alarm status (open). The alarm signal remains in place until the sensor is replaced (or cleaned). If "save alarm" is set on the leak display device, the alarm remains in place until the function button is pressed.

Malfunctions, such as power failure, a break or short circuit on the sensor or the corresponding connection cable or an incorrectly connected sensor (reversed poles), also cause an alarm signal.

---

<sup>1</sup> The permitted overpressure or negative pressure depends on the sensor in use (see data sheet for the sensor in the appendix).



### 3.2. Operating statuses (lamp display signals)

"Operation" signal lamp, green:	Lights up when there is a power connection.
"Alarm" signal lamp, red:	Lights up in case of an increase in liquid on the sensor (and in case of malfunctions).
"Alarm 2" signal lamp, red:	Lights up in case of increase of liquid on sensor 2 (leak display device C ONLY).

### 3.3. Function buttons

- (1) Test of the optical (and, if available, the acoustic) alarm signal  
Press function button once and hold it for approximately 10 seconds: the optical (and, if available, the acoustic) alarm signal is triggered.  
Only functions in "operation" status.  
Note: the signal lamp flashes before the optical and acoustic alarm signals are issued.
- (2) Commissioning<sup>2</sup>  
Before commissioning, make sure that the sensor(s) is/are free from liquid.  
Press the function button once and hold it until the red LED flashes quickly. Then release the button and immediately press it again briefly (releasing immediately after pressing).  
Note: after performing the commissioning sequence the "alarm" signal lamp flashes three times (on leak display devices B and C three acoustic signals are issued at the same time).  
Directly afterwards the connected sensor type(s) are displayed by flashing signals (see appendix A).
- (3) Switching off the acoustic alarm signal (C only)  
If the acoustic alarm sounds, press the function button once to switch off the acoustic signal. Press again to switch the acoustic alarm signal back on.  
Note (leak display device C only): If the alarm signal is issued for sensor 1 and the acoustic signal is acknowledged, the acoustic alarm signal is triggered again if the 2nd sensor is activated.

## 4. Installation instructions

### 4.1. Basic instructions

- (1) Installation and commissioning by qualified companies.
- (2) When installing, adhere to the valid accident prevention regulations.
- (3) Only connect sensors which are suitable for these leak display devices in accordance with appendix A.
- (4) The leak display device and sensor must be matched. The connected sensor is detected automatically by performing the commissioning sequence.

### 4.2. Installation of the leak display device

- (1) Either wall installation or installation on top-hat rail<sup>3</sup> (35 mm EN 50022) in the control cabinet, as near as possible to the position being monitored.

---

<sup>2</sup> The commissioning sequence has to be performed for each initial commissioning (type of sensor is detected automatically) and every time a sensor is replaced (even by one of the same type).

- (2) **NOT** in potentially explosive areas.
- (3) To allow the ventilation slots to work properly, make sure there is a side clearance of at least 2 cm from other objects and walls.
- (4) In closed, dry rooms and not directly next to sources of heat. Avoid excessive heat.
- (5) Installation is protective cabinet if installed outdoors or in wet rooms (at least IP 55 as per DIN 40050).
- (6) If installed in a protective cabinet, provide additional warning horn<sup>4</sup>, alternatively set up alarm forwarding with potential-free contacts.

#### 4.3. "Save alarm" function

- (1) "Save alarm" mean that when an alarm is issued, the alarm signal remains in place until the function button is pressed, even if the liquid has disappeared from the sensor. However, if the liquid is still present (when the function button is pressed), the alarm remains in place.
- (2) The leak display device is always supplied without the alarm saving function.
- (3) To switch to "save alarm" function:
 

Leak display device A:	Connect the wire jumper from terminal 9 to terminal 12.
Leak display device C:	Switch the coding plug (see (figure) from the left (as illustrated) and connect it on the right.

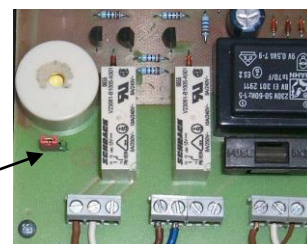

#### 4.4. Installation of the electrical connection cable

- (1) Use suitable cable: Liyy 2 x 0,75 mm<sup>2</sup> or equivalent
- (2) max. 30 m cable length between sensor and leak display device

#### 4.5. Electrical connection

- (1) 230 V – 50 Hz.
- (2) Permanently laid, e.g., no plug connections or switch connections.
- (3) Devices with plastic housing may only be connected with a fixed cable.
- (4) Adhere to the regulations of the electricity supplier<sup>5</sup>.

<sup>3</sup> The customer must provide the optical and acoustic alarm signal using potential-free contacts or alarm forwarding (using the potential-free contacts) must be used.

<sup>4</sup> Terminals for additional warning horn are only provided on leak display devices C. For leak display device A this can be implemented using the potential-free contacts with an external switch connected in series.

<sup>5</sup> For Germany: VDE regulations.

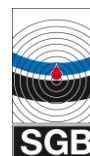

(5) Terminal assignment:

Indicating unit A		Indicating unit C	
1	Outer conductor (phase)	1	Outer conductor (phase)
2	Neutral conductor	2	Neutral conductor
3	Not assigned	5/6	External signal (in case of alarm the power supply is in place, can be shut off by pressing the function button).
5/4	Potential-free contact, opens in case of alarm or in case of power failure	11/13	Potential-free contact, opens in case of alarm or in case of power failure
5/6	Potential-free contact, closes in case of alarm or in case of power failure	11/12	Potential-free contact, closes in case of alarm or in case of power failure
7	Sensor - (brown cable from sensor)	31	- Sensor 1 (= brown wire from 1st sensor)
8	Sensor + (white cable from sensor)	32	+ Sensor 1 (= white wire from 1st sensor)
9/12	Jumper these terminals for "Save alarm" function	41	- Sensor 2 (= brown wire from 2nd sensor)
10/11	Option for serial data transfer	42	+ Sensor 2 (= white wire from 2nd sensor)

#### 4.6. Installation examples

See drawings

M1 – 105 500-520:

The different sensors are shown as examples which can also be connected to the leak display device.

M2 – 105 500-520:

Example illustration of leak display device C. Combination of different sensors on one leak display device of leak display device C as per appendix A.

M3 – 105 500-520:

Principle diagram for an oil separator, only for oils (light liquids) with flash point > 60°C (Germany: >55°C acc. to TRGS 509 and 751).

### 5. Commissioning

- (1) Once the electrical connection has been established, the green signal lamp lights up.  
Note: Depending on the setting, the alarm signal may be on or off, continue with the following points regardless of this.
- (2) Make sure that the sensor(s) is/are free from liquid.
- (3) Perform commissioning sequence as per chap. 3.3.
- (4) The LS 50 leakage sensor is in normal mode.
- (5) Carry out function test as per chap. 6.2.

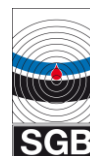

## 6. Operating instructions

### 6.1. General instructions

- (1) In case of a fault, inform the installation company or manufacturer.
- (2) Keep coarse soiling and/or objects which may compromise the function of the sensor away from the sensor.
- (3) Use a dry cloth to clean the leak detector/leak indicating unit with a plastic housing.

### 6.2. Maintenance / functional test

- (1) Only open the housing of the leak display device when it is isolated from the voltage.
- (2) Carry out the function test annually.
- (3) Press the function button and hold it for approximately 10 s (for longer than it takes to flash) so that the alarm signal is issued. (See chap. 3.3). Make sure that the alarm signal is issued.
- (4) release the function button. The alarm signal is retracted.
- (5) Remove the sensor and check for soiling. Clean it as necessary.
- (6) Check the sensor by immerse it in water. For better results, immerse it in the liquid which is to be detected (if justifiable).  
Exception: Do not carry out a wet test with sensor type KVS (inserted web). In this case the test has to be performed by inserting a metallic object (e.g., thin screwdriver) between the two layers of web. After inserting the metallic object, turn it parallel to the surface so that the two neighboring poles (or one pole and the housing) are bridged.
- (7) Make sure the alarm signal is issued. On leak display device C press the function button once. The acoustic alarm signal is retracted.
- (8) Replace, clean and dry the sensor.
- (9) The alarm signal is retracted automatically or, if the "save alarm" function is active, press the function button.
- (10) For leak display device C: Repeat sect. (6) to (9) with the second sensor.
- (11) Install the sensor.

### 6.3. Intended use

- Only suitable sensors in conjunction with leak display device (approved by AGB).
- The sensor and leak display device must neither be installed nor operated in a potentially explosive area.
- No liquids which can cause explosion must be monitored.
- The sensor and the leak display device are only provided for the applications stated in this documentation. You must not use the sensor and the leak display device for any other applications without the approval of SGB.





#### 6.4. Alarms/faults

- (1) In case of an alarm (occurrence of liquid or operating fault(s)) and optical alarm signal, and if available, an acoustic signal is triggered. The potential-free contacts are opened in alarm status.
- (2) For leak display device C: Shut off the acoustic signal by pressing the function button.
- (3) Remove any liquid which has leaked out. Remedy the cause of the fault and clean the sensor or replace the web as applicable.
- (4) Set up or install the sensor again.
- (5) Commissioning as per chap. 5 and function test as per chap. 6.

#### 7. Markings

- Electrical data
- Manufacturer or manufacturer symbol
- Year of manufacture (month / year)
- Serial number
- Certification number
- Symbol stipulated by the legislator

#### 8. Index

01.1	"Alarm" signal lamp, red
01.2	"Alarm" signal lamp, red
09	"Operation" signal lamp, green
24	Fuse T1A (5x20 mm)
36	"Commissioning" button
59	Relay
69	Buzzer
71	Function buttons
105	Control unit
106	Serial data transfer

A

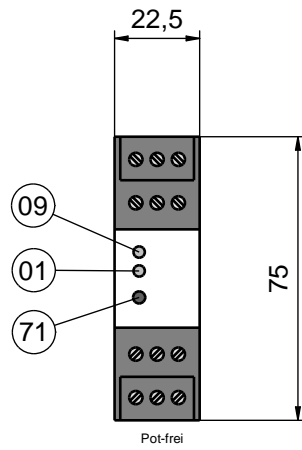

T = 100

C

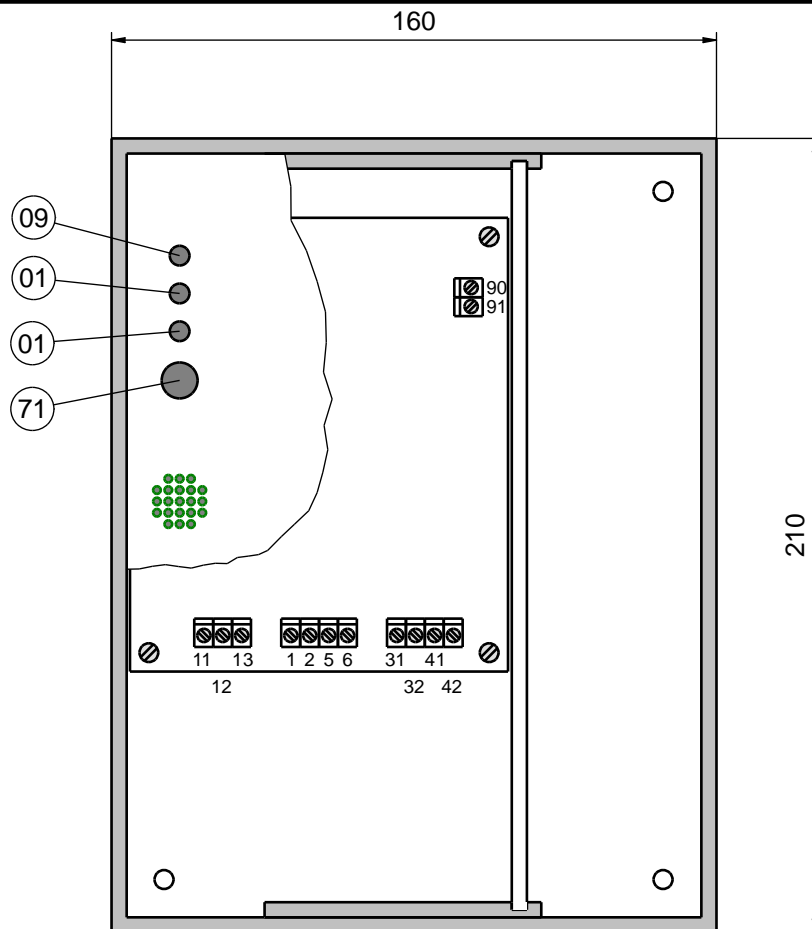

T = 50

Variante A oder C

Netz 230V

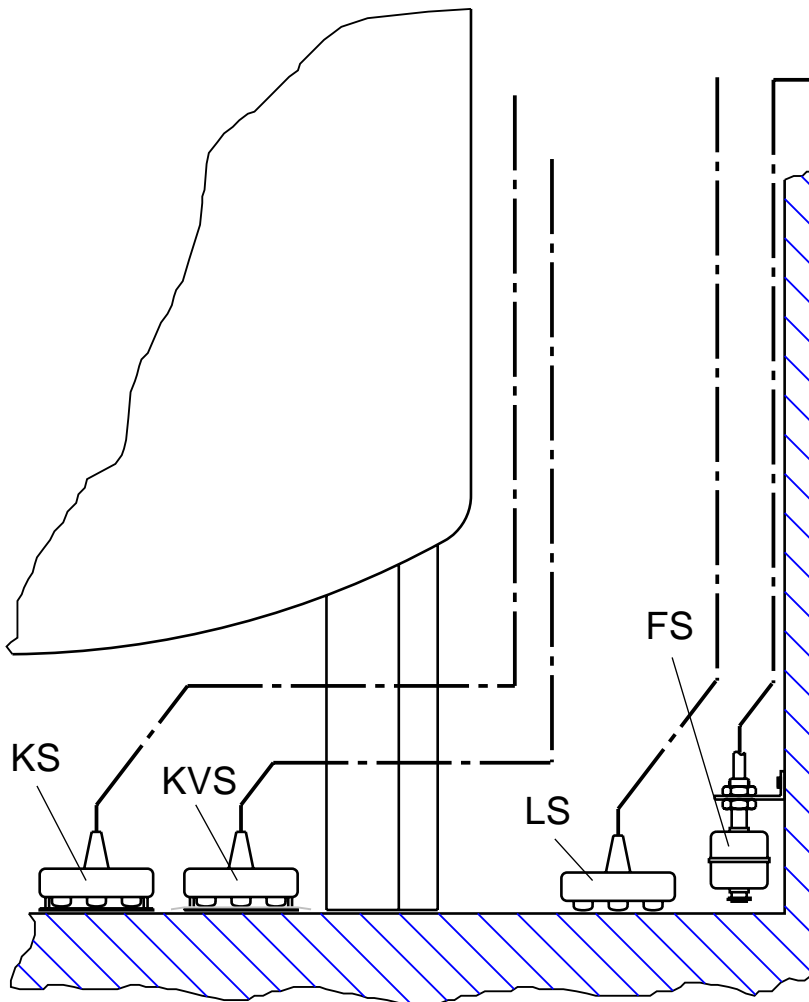

Variante C

Netz 230V

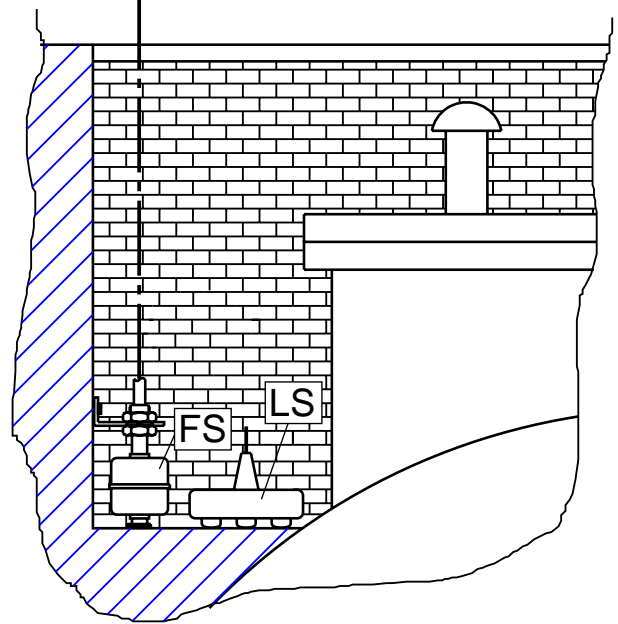
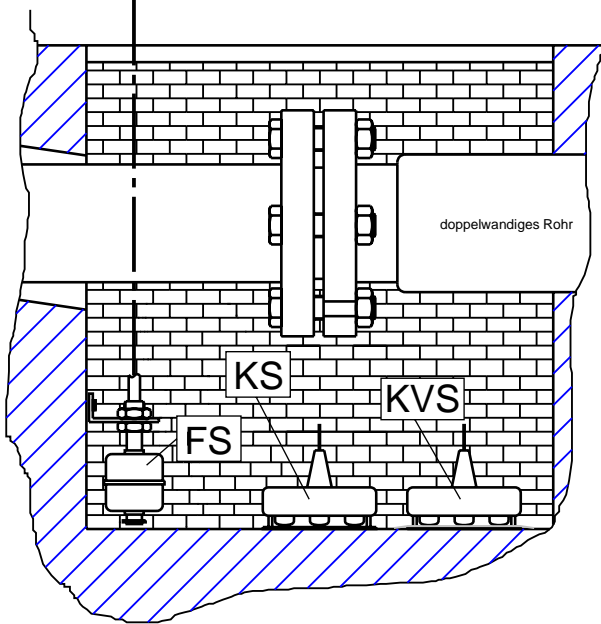

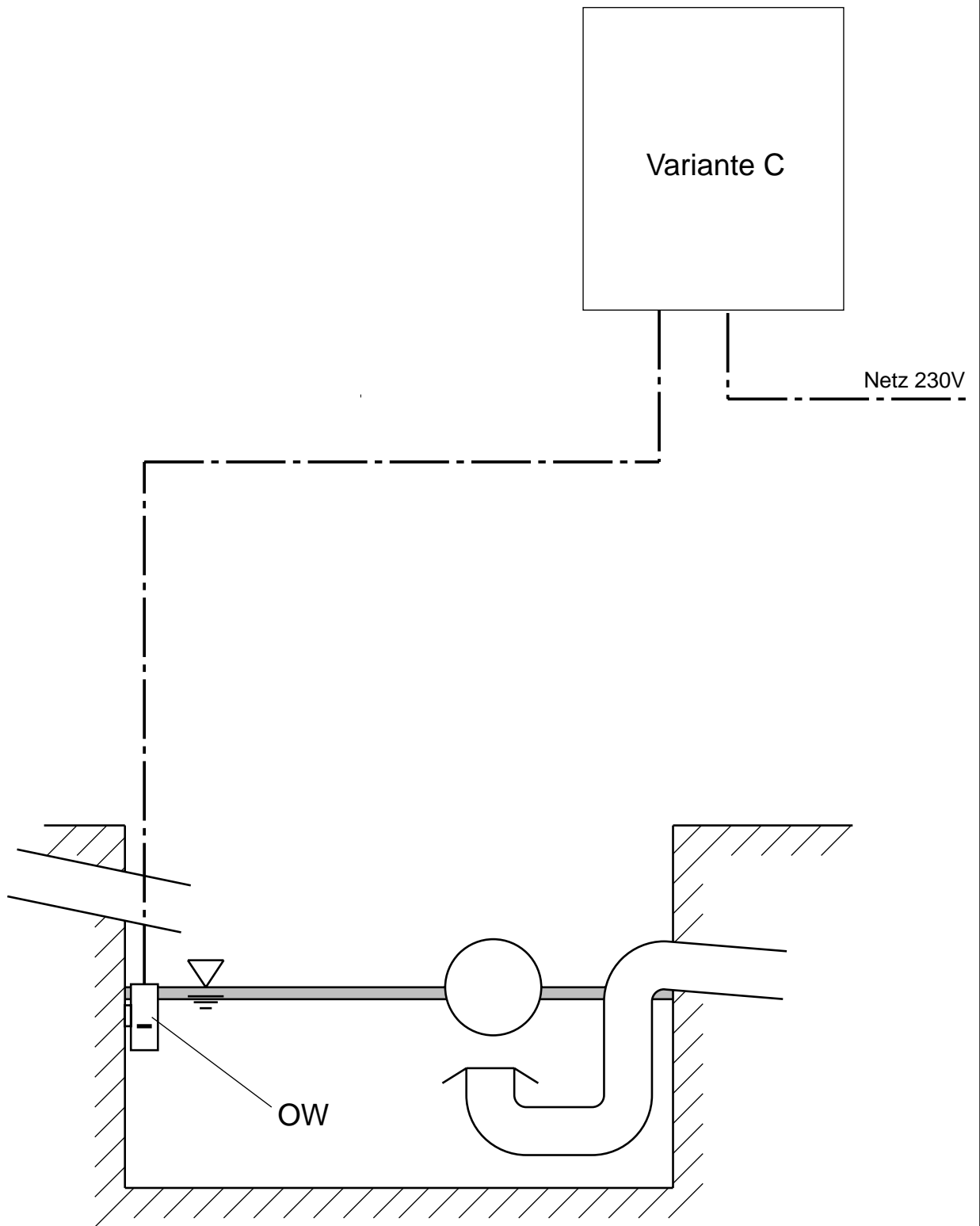

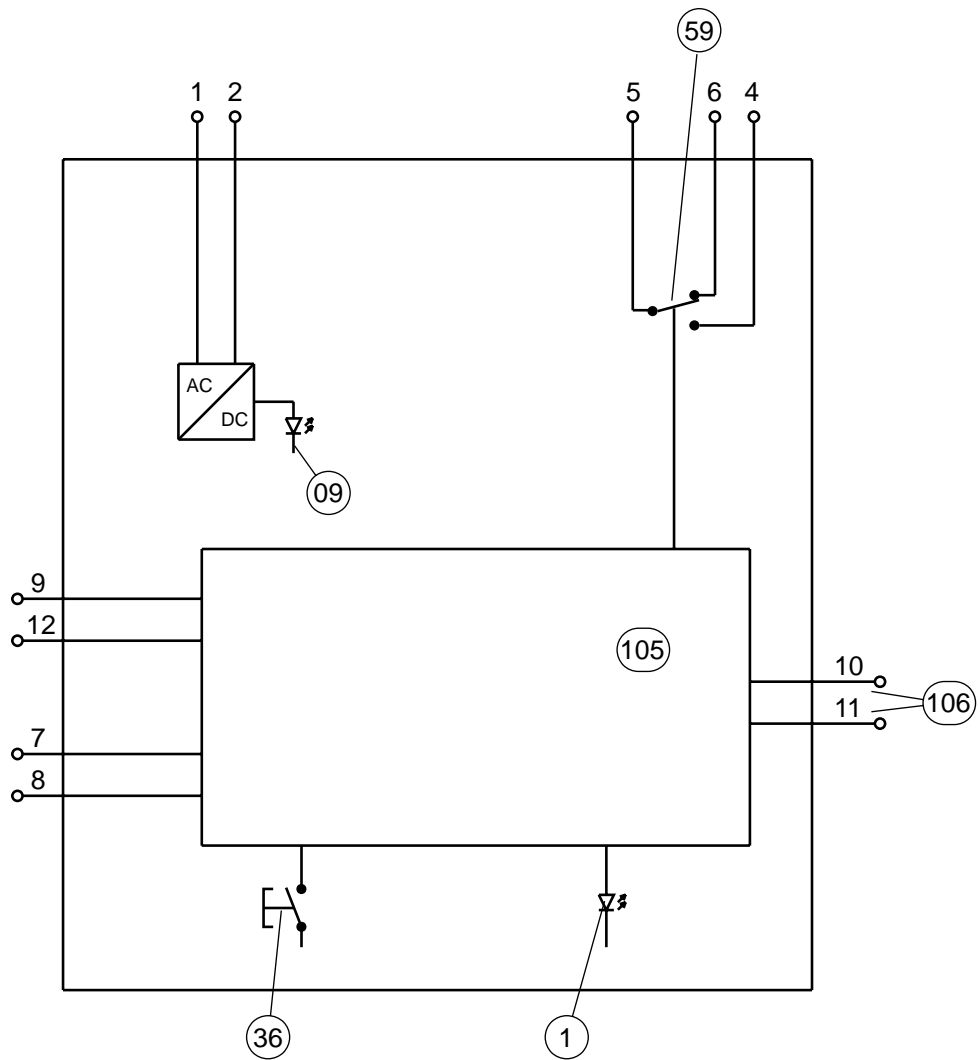

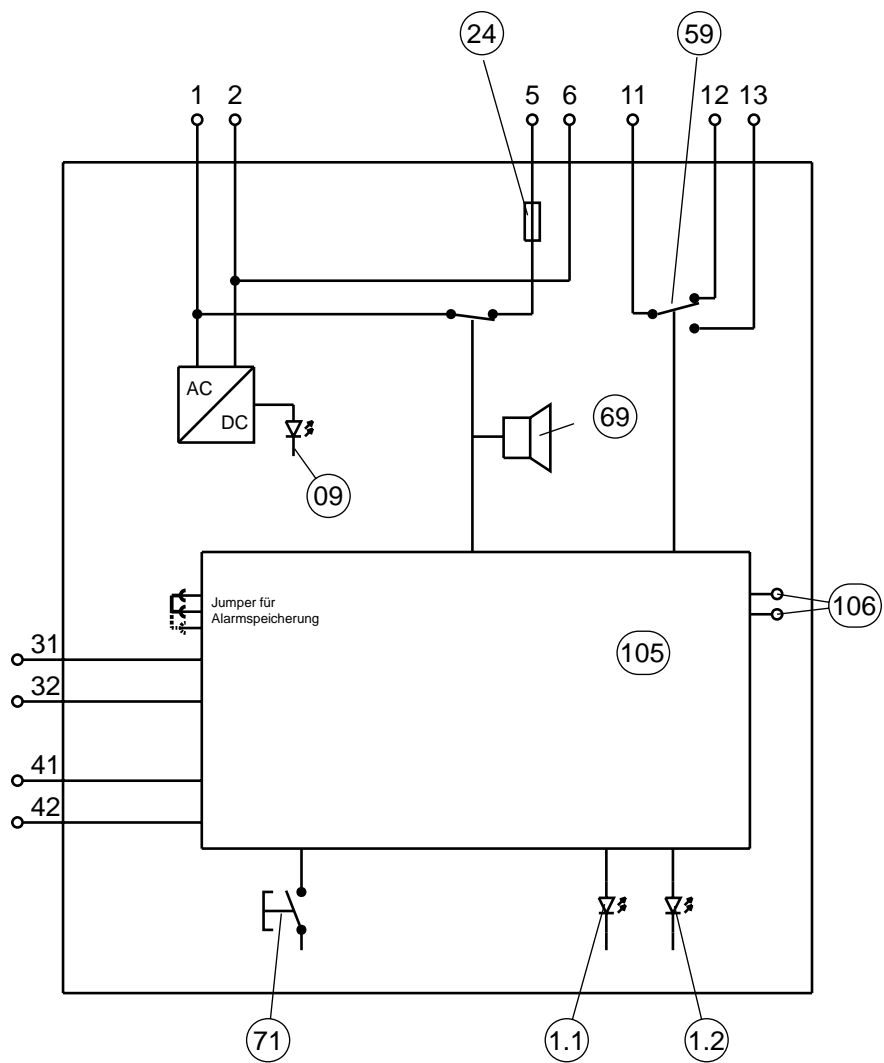



**A. Overview of the sensors which can be used**

- |  |             |
|--|-------------|
| 1. Float switch (type: FS)                             | Flashes 1 x |
| 2. Conductivity sensor (type: LS)                      | Flashes 2 x |
| 3. Capacitive sensor (type: KS)                        | Flashes 3 x |
| Capacitive sensor with web (type: KVS)                 | Flashes 3 x |
| 4. Oil/water sensor (type: OW) (sensor in preparation) | Flashes 4 x |

**A.1. Sensor combination options for leak display device C**

Terminals: 31 / 32	Terminals: 41 / 42
FS	FS
KS / KVS	FS
OW	FS
FS	LS
KS / KVS	LS
OW	LS



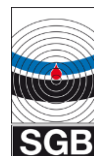

## **B. Type FS (float switch)**

### **B.1. Functional description**

The sensor is installed or set up in the space being monitored and connected to the leak display device. The leak display system is in normal mode after performing commissioning as per the description of the leak display device.

The sensor must be installed **vertically** (regardless of the type of installation!)

If there is an increase in liquid in the space being monitored, the float rises. As soon as enough liquid has entered to reach the activation level, the alarm signal is triggered.

If a fault occurs between the sensor and the leak display device or on the sensor itself, an alarm signal is issued.

### **B.2. Activation level / pressure resistance**

Activation height: < 3 cm, depending on the density of the leaking liquid

Density: > 0.8 kg/dm<sup>3</sup>

Pressure resistance: 4 bar (PVC)

10 bar (VA)

Temperature: -20°C to 60°C

### **B.3. Dimensions of the sensor**

Diameter (hanging installation on cable) 25 mm

Diameter (standing installation with base): 50 mm

Length (VA): 60 mm

Length (PVC): 80 mm

Depending on the design these specifications may vary. For more exact information and design variants refer to the SGB accessories catalogue.

### **B.4. Liquids which can be monitored / materials**

The liquids to be monitored must have a flash point > 60°C (Germany > 55°C acc. to TRGS 509 and 751) and must not form a potentially explosive vapour-air mixture in case of degassing. The liquid being monitored must neither have a tendency to adhere nor to crystallise.

This sensor is available in two material versions:

- PVC
- Stainless steel

One of these materials must be resistant to the stored liquid. However, different materials can be used on request.

### **B.5. Installation example**

See M1 – 105 500-520 and M2 – 105 500-520



## **C. Type LS (conductivity sensor)**

### **C.1. Functional description**

The sensor set up is or installed in the space being monitored and connected to the leak display device. The leak display system is in normal mode after performing commissioning as per the description of the leak display device.

If there is an increase in liquid in the space being monitored, the liquid establishes a conductive connection between the contacts (electrodes) and the probe. This change in the sensor circuit is detected by the leak display device and the alarm is triggered.

The probe must only be set up on NON-conductive surfaces. If the surface is conductive, a layer of suitable material must be placed underneath. The activation level increases by the thickness of this layer.

If a fault occurs between the sensor and the leak display device (short circuit / cable break), an alarm signal is issued.

### **C.2. Activation level / pressure resistance**

Activation height: < 5 mm

Pressure resistance: 1 bar (a suitable cable gland must be used)

Temperature: -20 °C to 70°C

### **C.3. Dimensions of the sensor**

Diameter: 60 mm

Height of sensor: 25 mm

Min. installation height: 60 mm

### **C.4. Liquids which can be monitored / materials**

The liquids to be monitored must have a flash point > 60 °C (Germany > 55°C acc. to TRGS 509 and 751) and must not form a potentially explosive vapour-air mixture in case of degassing. The liquid being monitored must be electrically conductive at  $\kappa \geq 10^{-4}$  S/cm.

The V2A must be resistant to the liquid being detected.

APPENDIX A:  
LEAKAGE SENSOR LS 50



Example list of liquids which can be monitored by this sensor:

Liquid	Flash point	Electr. conductivity [S/cm]	V2A resistance
2-amino ethanol	65°C	$11 \cdot 10^{-4}$ (25°C)	yes
Ethylene glycol	111°C	$1.16 \cdot 10^{-4}$ (25 °C)	yes
Tetrachloroethylene	No specification	$5.55 \cdot 10^{-2}$ (20°C)	yes
Ground water or tap water	No specification	Approximately $10^{-3}$	yes
1 molar HCL	No specification	$1.07 \cdot 10^{-2}$ (25 °C)	yes
H 2 SO 4, conc.	No specification	$1 \cdot 10^{-2}$ (25 °C)	yes
1 molar acetic acid	No specification	$1.3 \cdot 10^{-3}$ (25 °C)	yes
$10^{-3}$ molar HCL	No specification	$4.21 \cdot 10^{-4}$	yes

The above physical data is taken from data sheets. Different specifications may apply depending on the concentration or temperature. In case of doubt or liquids not listed a test must be carried out with the liquid being monitored.

In case of any doubt regarding resistance, the "save alarm" function should be set on the leak display device so that in case of an alarm the sensor can be subjected to a visual inspection.

### C.5. Installation example

See M1 – 105 500-520 and M2 – 105 500-520



## **D. Type KS (sensor with low activation level, capacitive)**

### **D.1. Functional description**

The sensor set up is or installed in the space being monitored and connected to the leak display device. The leak display system is in normal mode after commissioning as per the description of the leak display device.

If there is an increase in liquid in the space being monitored, this causes liquid to enter between the base plate and the sensor housing. When the underside of the sensor becomes wet due to the penetration of liquid into this gap, the capacity changes. When the capacity change exceeds a certain degree, the leak display device triggers an alarm signal.

As a design variant (type KVS), the gap between the sensor housing and sensor base plate can be equipped with a web which makes it possible for quantities of a few drops of a thin liquid to trigger an alarm signal.

If a fault occurs between the sensor and the leak display device (short circuit / cable break), an alarm signal is issued.

### **D.2. Activation level / pressure resistance**

Activation level, type KS: < 5 mm

Activation level, type KVS: Quantity of drops absorbed by the web

Pressure resistance: 1 bar (a suitable cable gland must be used)

Temperature: -20 °C to 70°C

### **D.3. Dimensions of the sensor**

Diameter, KS: 60 mm

Diameter, KVS: 70 mm

Height: 25 mm

Min. installation height: 60 mm

### **D.4. Liquids which can be monitored / materials**

The liquids to be monitored must have a flash point > 60 °C (Germany > 55°C acc. to TRGS 509 and 751) and must not form a potentially explosive vapour-air mixture in case of degassing. The liquid being monitored must be thin enough that it can penetrate into the gap between the underside of the sensor and the sensor base plate.

For it to function properly the liquid must have a permittivity of  $\epsilon_r > 2$ .

The V2A must be resistant to the liquid being detected.

APPENDIX A:  
LEAKAGE SENSOR LS 50



Example list of liquids which can be monitored by this sensor:

Liquid	Flash point	Permittivity $\epsilon_r$	V2A resistance
Acetamide	178°C	59 (83°C)	Yes
Acetoacetic acid	85°C	15.7 (22°C)	Yes
Acetophenone	82°C	17.39 (25°C)	Yes
Aniline	76°C	6.89 (20°C)	Yes
Benzonitrile	71°C	25.20 (25°C)	Yes
2-butoxyethanol	60°C	9.30 (25°C)	Yes
Chinoline	59°C	9.00 (25°C)	Yes
Acetic acid ethyl ester	91°C	26.7 (18°C)	Yes
Diesel	> 55°C	> 2 (25°C)	Yes
Diethylene glycol	140°C	31.69 (20°C)	Yes
N,N-dimethyl formamide	58°C	36.71 (25°C)	Yes
Ethylene glycol	111°C	37.7 (25°C)	Yes
Glycerine	176°C	42.5 (25°C)	Yes
Heating oil	> 55°C	> 2 (25°C)	Yes
m-cresol	86°C	11.8 (25°C)	Yes
o-cresol	81°C	11.5 (25°C)	Yes
p-cresol	86°C	9.91 (58°C)	Yes
Nitrobenzol	88°C	34.82 (25°C)	Yes
Octanol-(1)	81°C	10.34 (20°C)	Yes
Palm oil <sup>1</sup> (A.T. Süd GmbH)	> 100°C	No specification	Yes
Phthalic acid dibutyl ester	157°C	6.436 (30°C)	Yes
Salicylaldehyde	78°C	13.9 (20°C)	Yes
Sebacic acid dibutyl ester	178°C	4.54 (30°C)	Yes
Stearic acid dibutyl ester	160°C	3.111 (30°C)	Yes
o-toluidine	85°C	6.34 (18°C)	Yes
Triethylene glycol	165°C	23.69 (20°C)	Yes
Ground water or tap water	No specification	80.1(20°C)	Yes

The above physical data is taken from data sheets. Different specifications may apply depending on the concentration or temperature. In case of doubt or liquids not listed a test must be carried out with the liquid being monitored.

In case of any doubt regarding resistance, the "save alarm" function should be set on the leak display device so that in case of an alarm the sensor can be subjected to a visual inspection.

### D.5. Installation example

See M1 – 105 500-520 and M2 – 105 500-520

<sup>1</sup> Thinness of the liquid must be assured (at 30°C and above), flash point must be higher than the heating temperature and heating temperature must be below 60°C (max. operating temperature).

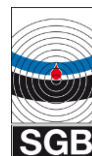

## **E. Type OW (oil/water sensor, capacitive)**

### **E.1. Functional description**

The sensor is installed in the space being monitored, and the sensor must be immersed in water (e.g. oil separator), and is connected to the leak display device. The leak display system is in normal mode after commissioning as per the description of the leak display device.

If the water in the monitored space is displaced so that the upper and lower markings of the sensor are exceeded by the liquid, there is a capacitive change on the sensor which is detected by the leak display device. When the capacity change exceeds a certain degree, the alarm signal is triggered.

If a fault occurs between the sensor and the leak display device (short circuit / cable break), an alarm signal is issued.

### **E.2. Activation level / pressure resistance**

Activation height:      Dependent on the installation height (the amount of water which has to be displaced in order to reach the marking)  
                                  I.e. because the sensor has to be covered with water, at least 5 cm of water has to be displaced for activation.  
                                  The value of 5 cm can of course be exceeded depending on the installation height in accordance with the local conditions<sup>2</sup>.

Pressure resistance: 1 bar (a suitable cable gland must be used)

Temperature:           5°C to 30°C

### **E.3. Dimensions of the sensor**

Diameter:              30 mm

Length:                 100 mm

### **E.4. Liquids which can be monitored / materials**

The liquids to be monitored must have a flash point > 60°C (Germany > 55°C acc. to TRGS 509 and 751) and must not form a potentially explosive vapour-air mixture in case of degassing.

For it to function properly the liquid must have a permittivity of  $\epsilon_r > 3$ .

The PVC material must be resistant to the liquid being detected. Other materials are available on request.

### **E.5. Installation example**

See M3 – 105 500-520

---

<sup>2</sup> The sensor should not be installed so that its marking is lower than the height of an 80% filling of the oil separator (with the product being separated).



**Technical data**

Power consumption	0.5 VA
External signal power rating, terminals 5/6 (LAE C)	230 V, 50 Hz, < 1 A
Fuse protection of the terminals AS:	1 A T
Power rating of potential-free contacts, terminals 4-6 (LAE A)	
Power rating of potential-free contacts, terminals 11-13 (LAE C)	max. 230 V, max. 2.5 A min. 10 mA at 5 V=
Sensor circuit:	5 V, 20 mA
Cross section of the connection cable	0.75 mm <sup>2</sup> to 2.5 mm <sup>2</sup>
Overvoltage category	2
Protection class	II

# EU DECLARATION OF CONFORMITY

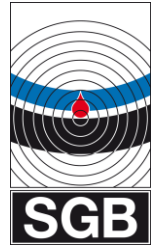

We hereby declare,

SGB GmbH  
Hofstraße 10  
57076 Siegen, Germany

under sole responsibility that the leak probe

**LS 50**  
**with sensors: FS, LS, K(V)S, OW**

complies with the basic requirements of the EC directives listed below.

This declaration will become null and void in case of any change to the device not approved by us.

Number / short title	Applied regulations
2014/30/EU EMC Directive	EN 61000-6-3:2007 / A1:2011 EN 61000-6-2:2006 EN 61000-3-2:2014 EN 61000-3-3:2013
2014/35/EU Low-voltage Directive	EN 60335-1:2012 / A11:2014 / A13:2017 / A1:2019 / A2:2019 / A14:2019 EN 61010-1:2010 / A1:2019 EN 60730-1:2011

Compliance is declared by

p.p.a. Martin Hücking  
(Technical Director)



**Note:**

By TÜV not certified  
translation of the German  
original version

**TÜV Nord**

Anlagentechnik

Hamburg, 17.02.2005  
-2102 stb  
Akte: 8237DV02340  
Auftrag Nr. 8100603726

## Test report

---

### 1 **Object**

Leak probe, comprising a leak display device and different sensors, which can be used as a safeguard for detecting liquids which are a hazard to water in spaces and the areas named in the manufacturer's technical description.

### 2 **Manufacturer**

SGB Sicherungsgerätebau GmbH Hof Straße 10 57076 Siegen

### 3 **Type designation**

Leak probe, type LS - 50

### 4 **Area of application**

Spaces and areas in which the penetration of liquids which are a hazard to water is to be signalled. Refer to the manufacturer's technical description from 01.07.2004 for details.

### 5 **Design**

The device produced by Sicherungsgerätebau GmbH with the designation LS-50 essentially comprises a probe section for immersing in the liquid being detected and the signal section (leak detector) for processing the measurements and issuing optical and acoustic signals.

The four following types of probes can be connected to the leak detector:

**Type FS (float switch)**

The probe consists of a Reed contact housed in the probe pipe and a permanent magnet installed in the moving part. When the Reed contact is switched the probe circuit opens and triggers the optical and acoustic signal. The float switch and alarm device are connected by a flexible cable. The float switch has to be installed on the wall in a position as near to exactly vertical as possible, at the lowest point of a control shaft or a collection space, in accordance with the manufacturer's installation instructions.

**Type LS (conductivity sensor)**

The probe comprises two conductive plate electrodes. The penetration of liquid into the intermediate space between the electrodes causes a current to flow. The current is evaluated by the connected leak detector and triggers an alarm.

**Type KS (capacitive sensor)**

The sensor comprises two capacitive plates (base plate and sensor housing). If liquid penetrates between the two plates, the capacity of the sensors is changed so that the leak detector can evaluate the capacity change and trigger an optical and acoustic alarm.

**Type OW (oil/water sensor)**

The sensor, which is continuously immersed in water, detects the presence of oil on the water surface. The difference in density between water and oil causes a capacity change on the sensor which is evaluated by the leak detector and causes an alarm.

The leak detector contains the power supply, the display elements an operating controls, the evaluation electronics, the potential-free relay contacts for connection of an external alarm and the components for the optical and acoustic alarm. There is an option for acknowledging the acoustic alarm.

Refer to the technical description from 01.07.2005 for power data and details on the construction of the device.

## **6**     **Liquids**

Liquids which are a hazard to water with a flash point  $>55^{\circ}\text{C}$ , liquids. The liquids are listed in appendix B of the technical description for the sensor types LS and KS.

The resistance of the sensors to the liquids being detected, their vapours or condensation must always be certified. Certification as per DIN 6601 is required for metallic sensors. The certification for float switches made of non-metallic materials is considered awarded if the liquids are listed in the respective valid release of the media lists of the Deutsches Institut für Bautechnik (DIBt).

The liquids being detected or their vapours must cause neither adhesion nor crystallisation during use of the float switch. Otherwise the criteria for use in the technical description, such as temperature, density, permittivity and conductivity must also be adhered to.

## **7**     **Test assignment**

The TÜV Nord testing department for leak display devices has been assigned to test the function and operational safety of the type LS-50 leak probe, including the electrical equipment, under the operating conditions stated in the technical description. Furthermore, the compliance of the leak probe with laws governing water as part of technical safety provisions as per Wasserhaushaltsgesetz § 19 h (German water management act) is also to be certified.

## **8**     **Documents**

Technical description for the LS-50 leak probe from 01.07.2005 with circuit diagrams and installation examples.

## **9**     **Bases for testing**

1. Zulassungsgrundsätze für Überfüllsicherungen (ZG-ÜS) (bases for approval for overflow safeguards) of the Deutsches Institut für Bautechnik, Berlin, issued May 1993, if required for assessment of the function of the leak probe.
2. Wasserhaushaltsgesetz (German water management act), new release from 19th August 2002.

## 10 **Testing**

The functional safety of the LS-50 leak probe for detection of liquids which are a hazard to water has been tested based on the documents submitted and a sample device with the sensor types listed in the technical description. Only the float switch has not been included in testing as this sensor has already been tested in conjunction with the type LS-10 leak detection device. The circuit diagrams and the sample device have been tested for compliance with DIN VDE requirements.

The assessment of the tests performed has shown that the leak probe is functionally safe and reliable and automatically trigger an optical and acoustic alarm when the sensors are immersed in liquid or when oil is present on the water surface. The prerequisite for the alarm signal is that the installation is performed in accordance with the installation instructions and commissioning including the commissioning sequence is performed as per the technical description.

In order to ensure that an alarm is triggered on the leak probe even in case of low quantities of liquid, the probe (except type OW) always has to be installed so that it is installed at the lowest point of a liquid-tight space, a collection pan or a monitoring room - which may be in the form of a shaft, a residual drainage bowl or a collection pit. In case of pipeline shafts which are permeable to liquids or safety pipes, the probe must be installed in a subsequently prepared control shaft, with the pipeline always laid with an incline to the control shaft along the whole length. The leak probe is also activated by water; the collection device must therefore be protected from rainfall, e.g. by a protective roof, so that no rain water reaches the probe and no false alarms are triggered.

The type OW leak probe must be installed so that the probe is always immersed in water. To do so the upper and lower markings on the probe body must be adhered to.

The type LS-50 leak probe has been subjected to a continuous test in accordance with the bases for approval for overflow safeguards. More than 15,000 switching procedures were performed, comprising the immersion of the individual sensors in the test liquid to trigger the alarm signal. EL heating oil, test oil and water were used as the test liquid in order to test functional safety/reliability. The continuous test was performed with temperature cycles of -25°C to +25°C and from +25°C to +70°C, alternating every 8 hours with a dwell time of 8 hours upon achievement of the final temperatures.

The alarm function triggered by the sensors can be regarded as satisfactory. Cable breaks and short-circuits on the probe circuit also trigger an alarm. The sound level for the acoustic alarm was measured at 72 dB(A) at a distance of 1 metre.

The leak probe is not suitable for use in potentially explosive areas. Sicherungsgerätebau GmbH already manufactures approved leak display devices on a vacuum and overpressure basis - which require similar procedures and test devices for manufacture and monitoring - and has the personnel and technical requirements for producing the aforementioned probes.

## **11 Assessment**

From the point of view of the testing department for leak display devices at TÜV Nord there are grounds for concern regarding the use of the type LS-50 leak probe as a safeguard for detecting liquids which are a hazard to water. The tests performed based on the bases for approval for overflow safeguards have produced positive results.

The type LS-50 leak probe is suitable for use as part of technical provisions in compliance with Wasserhaushaltsgesetz § 19 h (German water management act) for quick and reliable detection of leaks on plants for storage of liquids which are a hazard to water if the following conditions are met:

- 11.1. The leak probe must be manufactured in accordance with the technical description from 1st July 2004 provided for this test, including the circuit diagrams and individual partial drawings.
- 11.2. The manufacturer must ensure the consistent quality of the manufactured devices based on the quality assurance system.
- 11.3. If deficiencies are identified during testing, measures for eradication of the deficiencies must be taken and the respective tests must be repeated immediately. Devices which do not meet with requirements must be rejected.

- 11.4. Each leak probe must be marked permanently and clearly in the appropriate position with the following information:
- Manufacturer
  - Type
  - Manufacturing or production number
  - Year of manufacture
  - Electrical operation data.
- 11.5. The leak probe is suitable for detection of liquids which are a hazard to water under atmospheric conditions. The compatibility of the probe materials used with the liquids to be detected must be certified. The basis for certification of the compatibility of the probes when produced with metallic materials is DIN 6601. For non-metallic materials the respective issue of the media lists of the DIBt apply.
- 11.6. When installing the device it is essential to ensure that the probe is always installed at the lowest point of the liquid-tight collection space or shaft - except for probe type OW - so that the probe can be activated by even low quantities of liquid. The collection space must be set out with an inclination to the installed location of the leak probe if possible.
- 11.7. The OW probe must be installed so that the water level is guaranteed to fluctuate between the upper and lower probe markings.
- 11.8. When installing the probe the installation instructions in the technical description must be adhered to. If possible, the installation bracket supplied by the manufacturer must be used to fasten the float switch. Otherwise the set minimum distance from the wall of 5 mm must be adhered to. If the collection equipment is accessible on foot, the probe must be protected from mechanical damage and the connection cable between the probe and leak detector must be laid in a protective pipe.
- 11.9. After installation of the probe, a function test with a sample of the liquid being detected should be performed if possible. The alarm signal must be checked.
- 11.10 The installation and maintenance of the type LS-50 leak probe must only be performed by specialist companies as per WHG § 19 I. The user must be provided with installation and test certification, including the technical description, certifying the proper installation and the function.

11.11 The leak probe must be checked by the user at regular intervals for readiness for operation, damage, corrosion or soiling. The device must be subjected to a functional test by immersing the probe in test liquid at least once per year.

11.12. If the leak probe is part of a plant subject to inspections, the leak probe must be included in the initial plant inspection and all recurring plant inspections.

Notes: Testing must be repeated in case of any changes to the construction, the materials and the conditions for use.



Straube  
of TÜV Nord GmbH.  
Testing authority for construction products

viewed:

Fassl

# Warranty

---

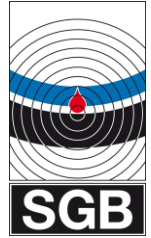

Dear customer,

You have purchased a high-quality leak detector from our company.

All of our leak detectors undergo a 100% quality control examination. The type plate with the serial number is only affixed after all test criteria have been complied with.

The **warranty period** for our leak detectors is **24 months**, beginning on the date of installation on site. The maximum warranty period is 27 months from our date of sale.

Our warranty will be effective only if the customer submits to us the functional report or test report on initial putting into service, prepared by a recognised company specialised in water and water protection systems, including the serial number of the leak detector.

The warranty shall not apply in the event of faulty or improper installation or improper operation, or if modifications or repairs are carried out without the manufacturer's consent.

Our warranty does not include parts, which may be perished premature due to their consistence or category of usage (e.g. pumps, valves, gaskets, etc.). Furthermore, we are not liable for defects or corrosion damages caused by humid or inappropriate installation environments.

The warranty is also subject to our General Terms and Conditions of business (see these online at: <https://sgb.de/en/contact/generaltermsandconditions>).

In case of malfunction, please contact your local specialist company:



Stamp of the specialist company

Yours sincerely

**SGB GmbH**

Hofstr. 10  
57076 Siegen  
Germany

T +49 271 48964-0

E [sgb@sgb.de](mailto:sgb@sgb.de)

W [sgb.de](http://sgb.de)

---